

QUICKPOINT

FLEXIBLE HIGH-PERFORMANCE GRINDING MACHINE



FLEXIBILITY BROUGHT TO A POINT



High-speed grinding with QUICKPOINT combines JUNKER precision with maximum flexibility. QUICKPOINT machines can be used for a wide range of applications, and at the same time boast impressive productivity. The result: versatility and excellent workpiece quality.

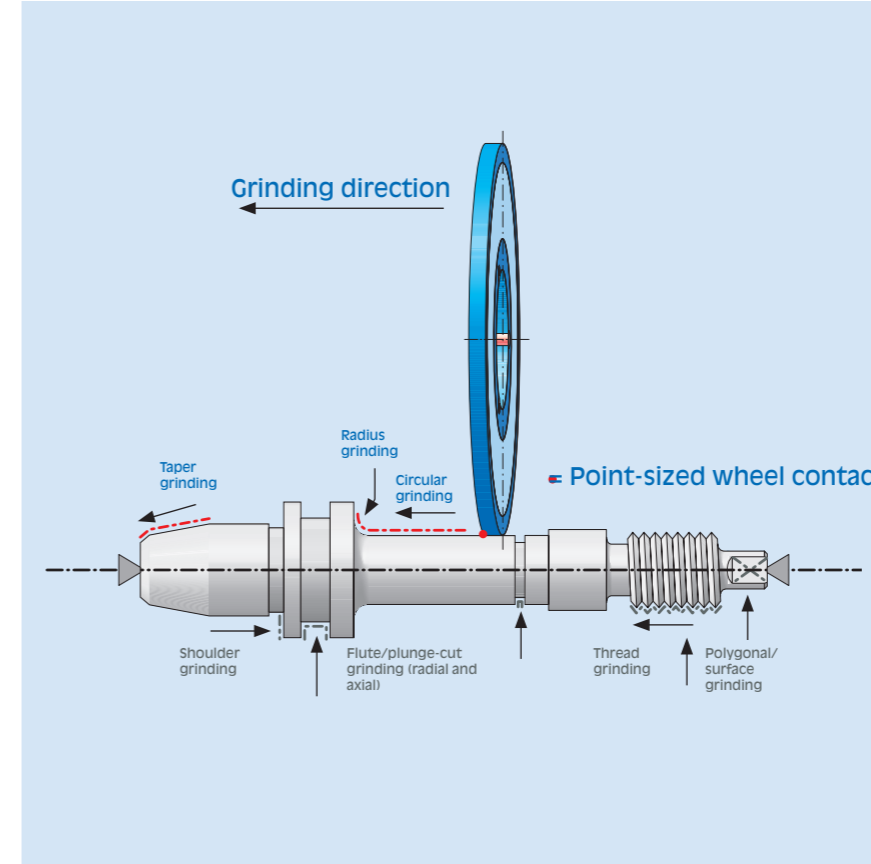

QUICKPOINT standard operations are shoulders, tapers, chamfers and plunge cuts. In addition, flute and thread grinding, as well as polygonal and surface grinding can also be integrated.

THE QUICKPOINT PRINCIPLE

Grinding with QUICKPOINT is OD high-speed grinding using single-point contact in the finish grinding area. QUICKPOINT works with an extremely low-wear CBN or diamond wheel just a few millimeters wide. By creating a relief angle, the contact zone between wheel and workpiece is reduced from a contact line to a contact point.

FOR THE AUTOMOTIVE INDUSTRY – HIGH PRODUCTIVITY

Large series manufacture demands high performance – with complete QUICKPOINT grinding in a single clamping set-up, you also get flexibility! This is how QUICKPOINT allows for lean manufacturing and makes investments in inflexible special machines a thing of the past.

FOR SMALL AND MID-SIZED COMPANIES – HIGH FLEXIBILITY

QUICKPOINT is also the ideal solution for small and mid-sized companies, as well as contractors with frequently changing grinding projects. QUICKPOINT is fast and easy to re-tool, lends itself to a wide variety of applications and is individual adaptable to always offer the right capability.

Customer advantages

- **High-speed grinding** with sophisticated CBN/diamond grinding technology
- **Excellent part quality** with one-time clamping of workpieces
- **Maximum availability** with fully automated grinding process
- **Fast grinding speed** with thorough coolant penetration of active grinding zone
- **Fast re-tooling** with highly flexible machine concept

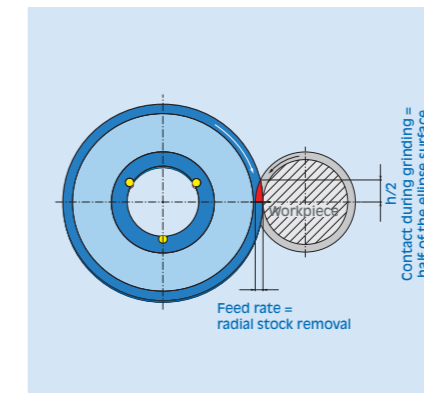
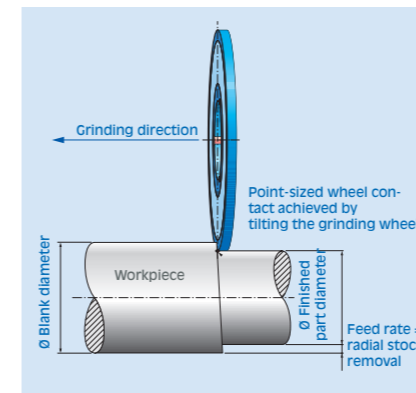

THE PINNACLE OF VERSATILITY

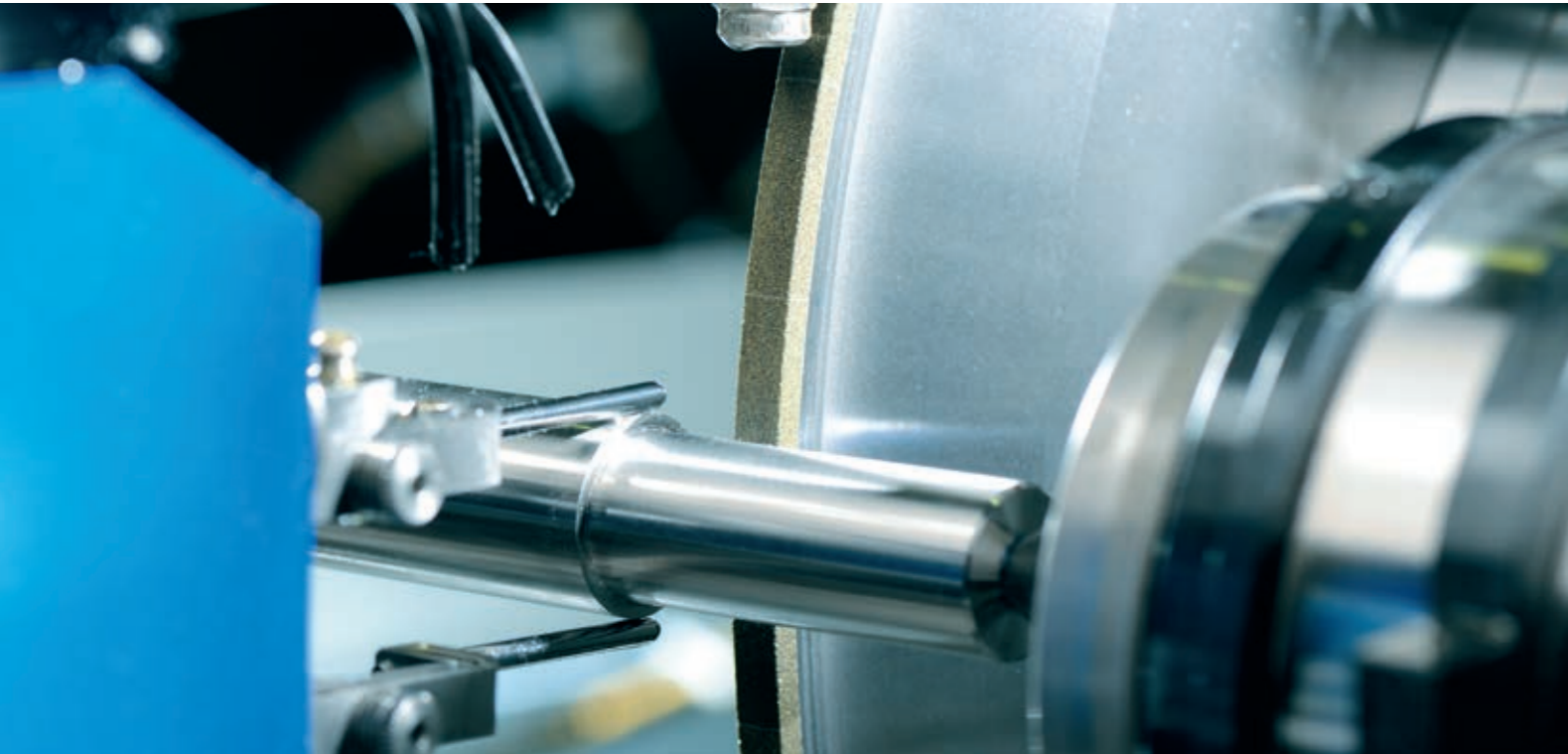

OD grinding with QUICKPOINT

AREAS OF APPLICATION

- Automotive manufacturers and suppliers
- Precision tooling industry
- Transmission manufacturing
- Machine tool manufacturing
- Textile machine manufacturing
- Printing machine manufacturing
- Electrical industry
- Carbide and ceramic processing industry

MATERIALS AND OPERATIONS

Practically any material and combination of materials can be ground with QUICKPOINT: steel, aluminum, carbide, industrial ceramic, sintered material, plastic, glass. With carbide grinding, the advantages are particularly high – up to 600% higher performance. When combined with other JUNKER technologies, QUICKPOINT machines can also grind surfaces, polygons, reliefs and tightening threads. Standard grinding operations: shoulders, tapers, chamfers and plunge cuts.

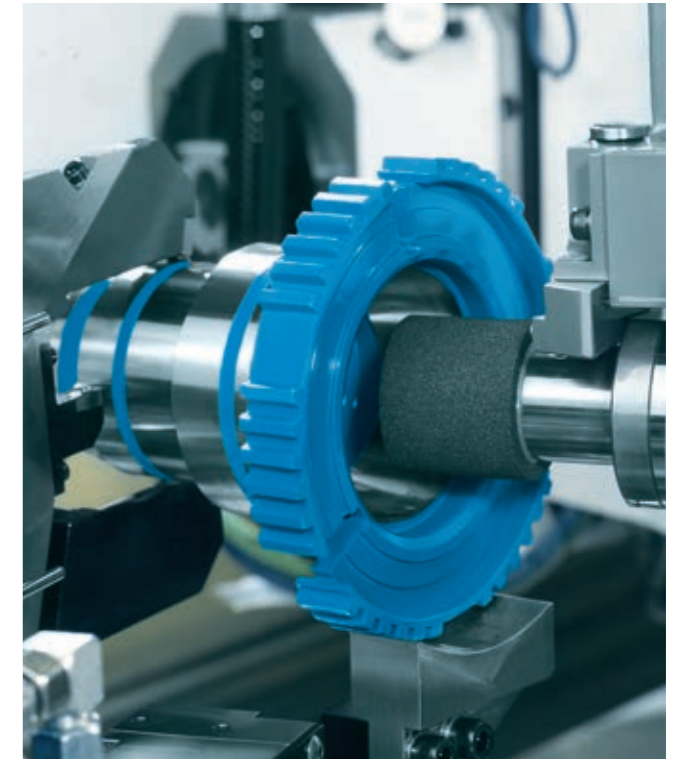

ID grinding with QUICKPOINT

Complete grinding in a single clamping set-up

With modified grinding wheels, QUICKPOINT machines can also be used for complete grinding. This allows for plunge grinding, thread grinding, shape and non-circular grinding, among others, all in a single clamping set-up. ID grinding operations are also possible.

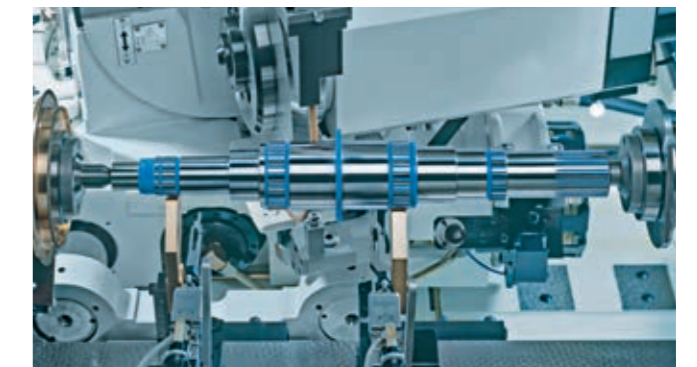
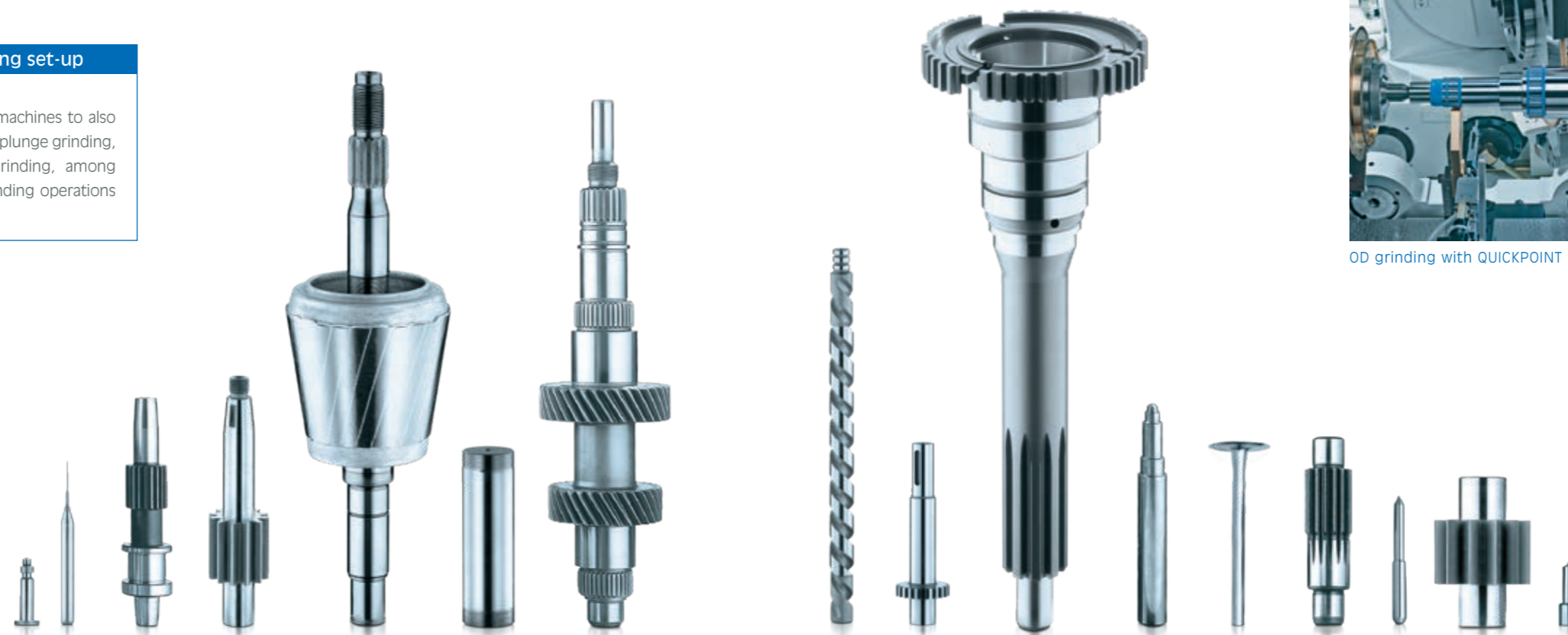

OD grinding with QUICKPOINT

SOPHISTICATED TECHNOLOGY FOR ECONOMICAL GRINDING

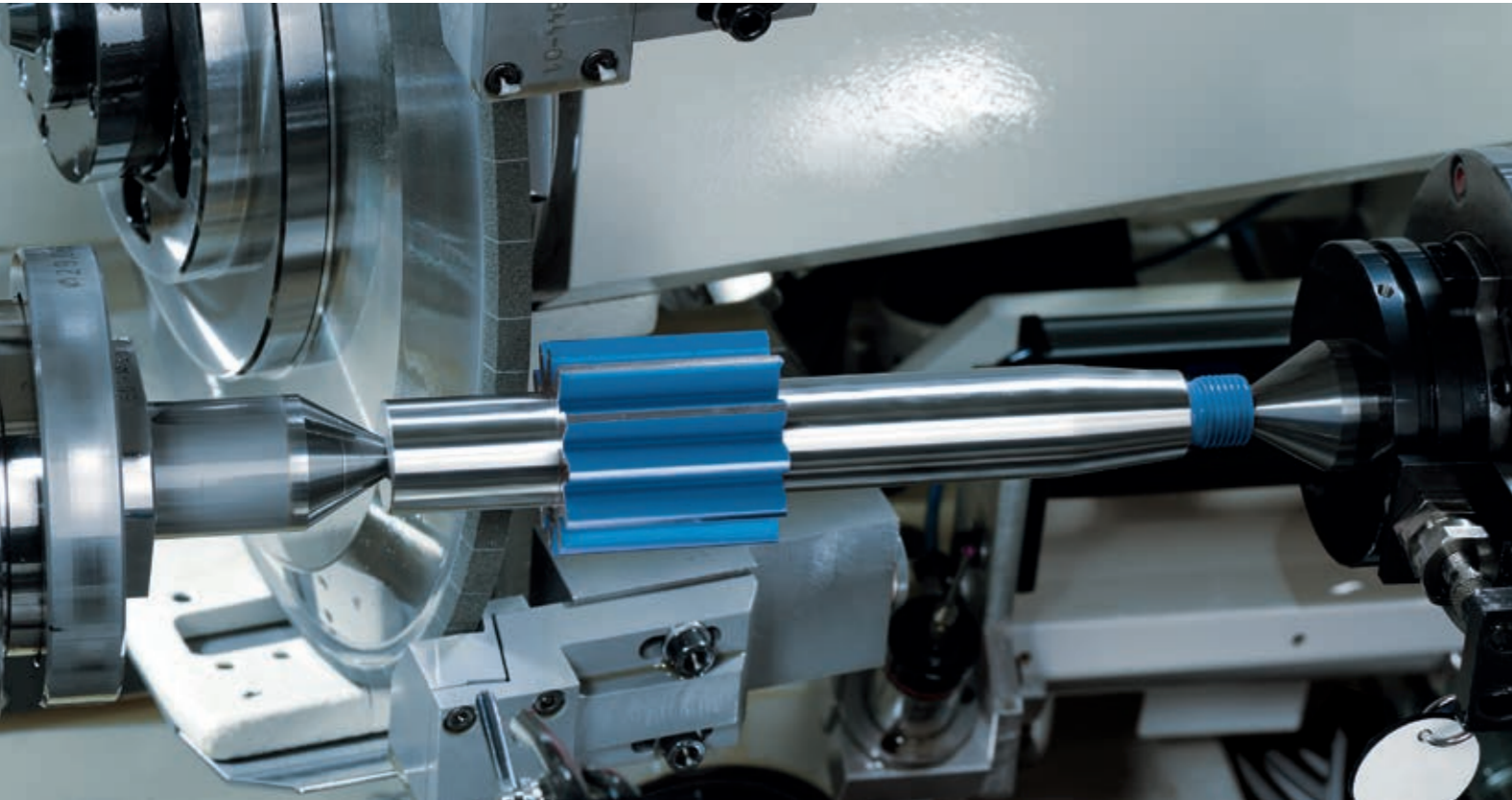

QUICKPOINT technology for precision grinding

VERSATILITY PAYS

With a wide selection of wheelhead combinations, the QUICKPOINT line offers OD grinding solutions for practically any application: from the compact QUICKPOINT 1000 for smaller parts, to the QUICKPOINT 5000 for medium-sized parts, all the way to the QUICKPOINT 6 for large workpieces. Wherever you use a QUICKPOINT, it guarantees a low-cost manufacturing process.

STABLE MACHINE BASE

Each QUICKPOINT machine features a highly torsion-resistant polymer concrete stand that dramatically reduces vibrations. This allows for dynamic and high-precision grinding operations and provides the stable foundation required to attain the best possible part qualities.

FAST CHANGEOVER FOR LOW DOWNTIMES – THE 3-POINT MOUNTING SYSTEM

This system has been applied to the wheelhead, workhead and tailstock and shortens the machine's tooling times.

- Fast changeover and tooling times (< 2 min for center points, < 20 min for grinding wheels)
- Easy-to-mount
- Optimal centering
- Axially mounted with screwed-on grinding wheel flange, allowing changeover in rotational direction
- Concentricity: $\leq 2/1000$ mm

THE DRESSING SYSTEM – A DECISIVE FACTOR

Precise and fast dressing determines the efficiency of a CBN or diamond grinding machine. As a pioneer of this grinding method, over the years, JUNKER has acquired and further developed the know-how that it requires. From circumference, surface and radii to profile dressing: for each QUICKPOINT application, we also offer the optimal dressing system.

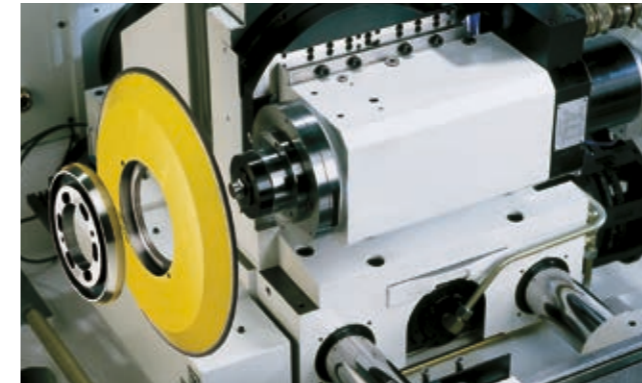

Fast changeover of the wheel with the 3-point mounting system



COMMERCIAL ADVANTAGES

- Major investment savings with lean manufacturing: nearly all workpiece contours can be ground with a single grinding wheel in just one clamping set-up
- Software directly imports workpiece contour
- High rate of utilization at 88 – 95%, that is 3 – 8% higher than with conventional grinding
- Higher productivity attained by grinding in a single clamping set-up
- Simplified logistics: no re-clamping, no need for different machines
- Low tool costs thanks to long tool lives
- High production reliability and flexibility with individual machines instead of a production line
- Fast tooling times, since no workpiece carrier required

TECHNICAL ADVANTAGES

- High flexibility for shoulders, tapers, chamfers, plunge cuts, reliefs, tightening threads, surfaces and polygons
- Fast grinding speed with thorough coolant penetration of active grinding zone
- Increased quality with complete grinding in one clamping set-up
- Complete grinding, including both ends of the part (since there is no workpiece carrier involved)
- High surface finish

THE GRINDING SPINDLE – RIGID AND PRECISE

- Up to three high-speed grinding spindles
- High cutting speed – up to 140 m/s
- Automatic dynamic balancing system
- 3-point mounting system

THE WHEELHEAD – ACCURATE AND DYNAMIC

- Hydrostatic circular guides with a 5-year guarantee with proper handling
- Infeed with micron precision and no stick-slip effect

THE WORKHEAD

- With workpiece carrier to get in the way: hydraulic clamping between the centers of the power workhead and the revolving tailstock is all you need
- Direct drive work spindle mounted on anti-friction bearings

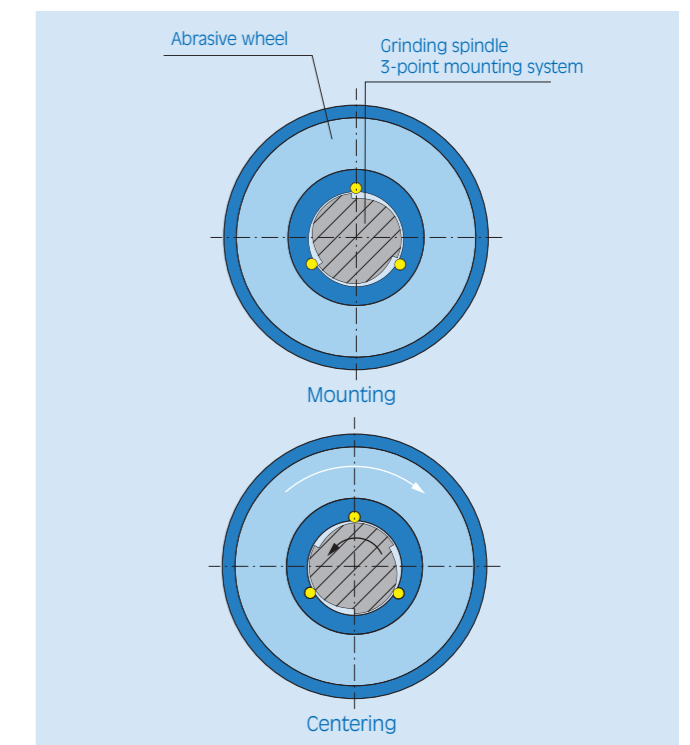

Abrasive wheel assembly: 3-point mounting system
(also suitable for wheels with non-standard bores)

JUNKER'S CENTRALIZED CNC SYSTEM CONCEPT



A COMPREHENSIVE OPEN SYSTEM

The idea: central control technology for all components in the grinding machine. All data and information is entered using the Erwin Junker Operator Panel. On the QUICKPOINT machines, this makes up the user interface for a FANUC CNC-control system.

TELESERVICE – FAST AND EFFECTIVE

Your main go-to for all questions and issues is JUNKER Services. When required, all of the machine status data can be analyzed online. JUNKER provides this service to increase machine availability while keeping service costs down.

ERWIN JUNKER OPERATOR PANEL – STANDARDIZED FOR ALL MACHINES

- Graphic interface and interactive processes for programming and operation
- Reduced training costs
- Minimizes the risk of operator errors
- Quick changeover and set-up
- Storage of all grinding parameters
- Machine programming, can also be done centrally, i. e. basic mask for process engineering

Advantages of the hardware and software concept

- All components are accessible via Teleservice
- Identical operation of different machines, regardless of the controls used
- Standardized user interface for all components
- Automatic data backup, including settings for all components from third-party vendors

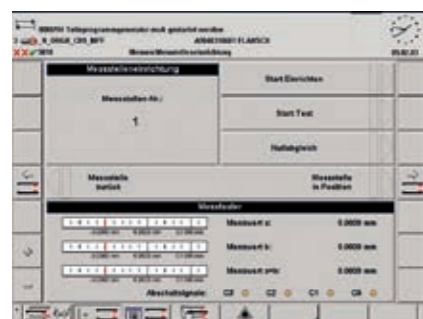

Configuring the measurement systems

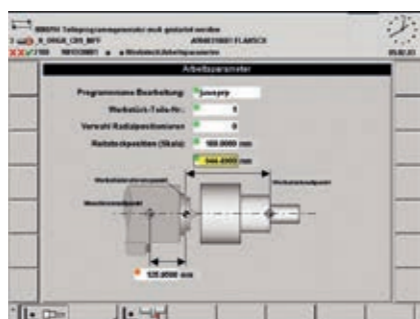

Grinding parameter entry

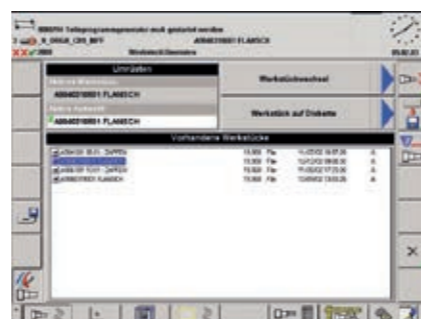

Importing the new parts program

VARIABLE EQUIPMENT AND INDIVIDUAL OPTIONS

STANDARD EQUIPMENT

- Fully automatic dressing cycle
- 3-point mounting system for the grinding wheel
- Hydrostatic circular guides (X-axis)
- Flat/prismatic guide (Z-axis)
- Axially mobile tailstock
- Clamping pressing hydraulically adjustable
- Erwin Junker Operator Panel
- Sinumerik or Fanuc controls

OPTION: JUNKER LOADING SYSTEM

- Interior loading gantry for reliable productivity
- External loading system can be modularly docked, half or fully automatic at customer request
- Axial positioning device, diameter measuring device
- C-axis on workhead
- Surface dresser
- Steady rests

RELIABLE FIRE PROTECTION CONCEPT: "THE JUNKER SAFETY SYSTEM"

Since the machines partly use oil for coolant, there is a risk of fire and explosion. The JUNKER safety system prevents damage to machines and facilities. In the case of explosion, the machine interior is automatically sealed off, preventing fire from breaking out (tested by the Institute for Safety Technology IBExU). Upon request, additional extinguishers (CO₂ or water-atomizing) and exhaust filters can be installed.

Option: Carbon grinding wheels

All QUICKPOINT versions can also be equipped with carbon grinding wheels. Technical advantages are higher cushioning and reduced weight. There is also an important economic aspect: higher productivity thanks to longer tool life and dressing cycles, as well as significantly fewer wheel changes.

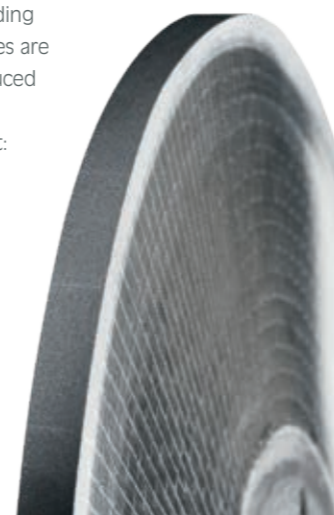

QUICKPOINT with automation



In-process gauging for maximally precise manufacturing

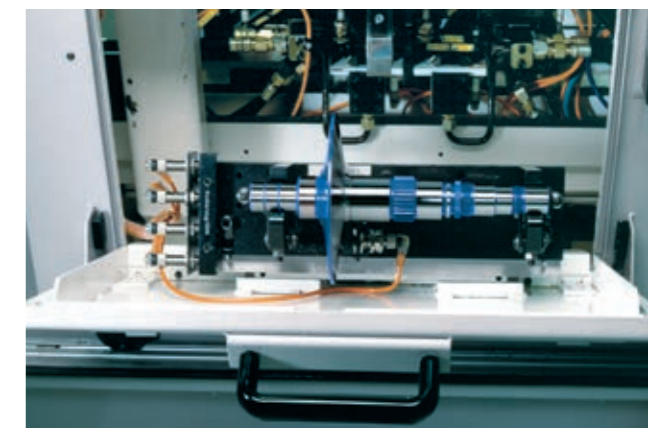

QUICKPOINT 5000 with pivoting hatch cover on the front of the hood for manual loading and unloading

TECHNICAL SPECIFICATIONS



PLATFORM	1S	1000	3000	5000	6XS	6S	6L	6XL
Available wheelhead versions	/10 /10i /20 /30 /50	/10 /10i /20 /30	/10 /10i /20 /30 /40 /50 /50S /60	/10 /10i /18 /20 /30 /40 /50 /50S /60	/10 /10i /18 /20 /30 /40 /50 /50S /60	/10 /10i /18 /20 /30 /40 /50 /50S /60	/10 /10i /18 /20 /30 /40 /50 /50S /60	/10 /10i /18 /20 /30 /40 /50 /50S /60
Quantity wheelhead	1	1	1	1	1	1 2	1 2	1 2
Grinding length	150 mm	150 mm	500 mm	700 mm	500 mm	1.000 mm 750 mm	1.800 mm 1.500 mm	2.800 mm 2.500 mm
Clamping length	150 mm	150 mm	500 mm	700 mm	600 mm	1.200 mm	2.000 mm	3.000 mm
Center height	100 mm	100 mm	150 mm	170 mm	170 mm	170 mm	170 mm	170 mm
Workpiece weight	5 kg	5 kg	15 kg	130 kg	130 kg	150 kg	200 kg	300 kg
Grinding wheel diameter-Ø	350 mm	350 mm	350 mm	500 mm	500/700 mm	500/700 mm	500/700 mm	500/700 mm
Swing diameter-Ø	80 mm	80 mm	150 mm	280 mm	280/320 mm	280/320 mm	280/320 mm	280/320 mm
W x D x H mm	1.800 x 2.500 x 2.100	1.500 x 2.500 x 2.100	3.400 x 2.800 x 2.200	4.900 x 3.400 x 2.350	3.260 x 3.750 x 2.450	4.100 x 3.750 x 2.450	4.900 x 3.750 x 2.450	6.400 x 3.750 x 2.450
Weight	10.000 kg	9.000 kg	12.000 kg	17.000 kg	20.000 kg	25.000 kg 28.000 kg	28.000 kg 31.000 kg	31.000 kg 34.000 kg

WHEELHEAD VERSIONS

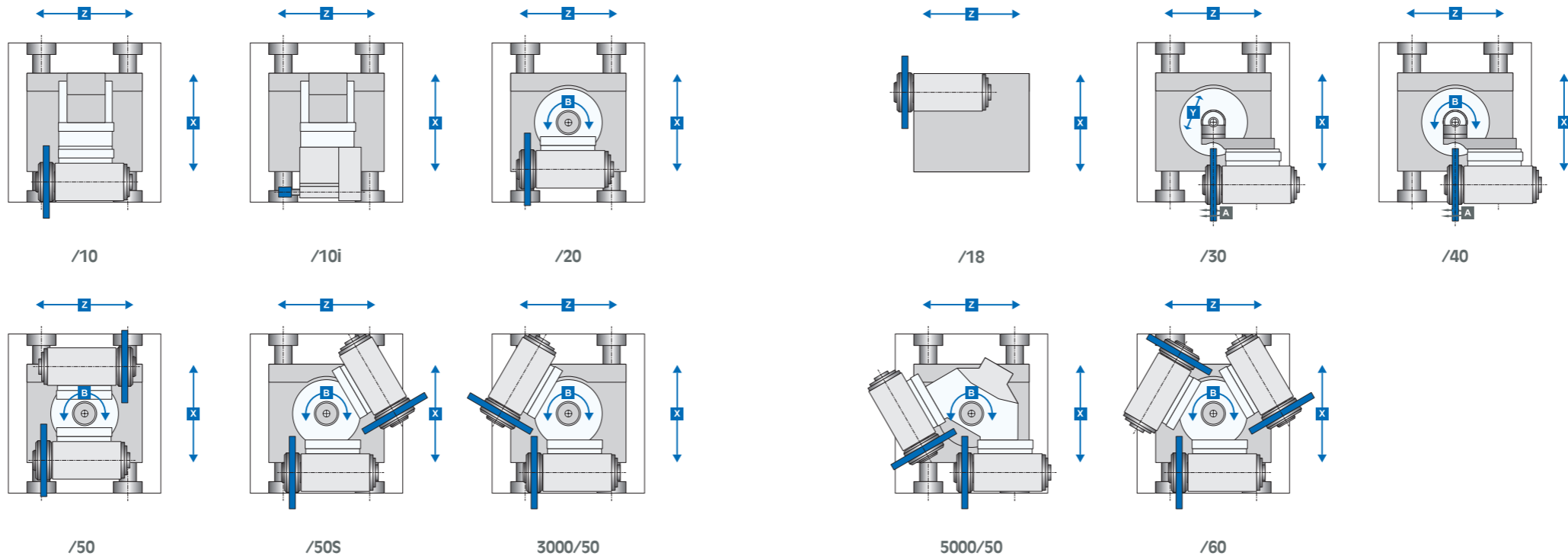

EUROPE

Erwin Junker Maschinenfabrik GmbH

Junkerstraße 2
77787 Nordrach
Germany

info@junker.de
+49 7838 84-0

Erwin Junker Grinding Technology a.s. Plant Holice

Pardubická 332
534 01 Holice
Czech Republic

info@junker.cz
+420 466 003-111

Erwin Junker Grinding Technology a.s. Russia Branch Office

Prospekt Tolbukhina 17/65
150000 Yaroslavl
Russian Federation

info@junker-russia.ru
+7 4852 206121

**JUNKER
GROUP**

Erwin Junker Makina Sanayi Ticaret LTD. ŞTİ.

Esentepe Mah.
Milangaz Cad. No:75
Monumento
Kartal/Istanbul
Turkey

info@junker-turkey.com.tr
+90 216 5042811

LTA Lufttechnik GmbH

Junkerstraße 2
77787 Nordrach
Germany

info@lta-filter.com
+49 7838 84-245
www.lta-filter.com

LTA Industrial Air Cleaning Systems s.r.o.

Lidická 66
252 68 Středokluky
Czech Republic

info@lta-filter.com
+420 233 012-113
www.lta-filter.com

AMERICA

Erwin Junker Machinery, Inc.

2541 Technology Drive, #410
Elgin, IL 60124
USA

info@junker-usa.com
+1 847 4880406

Erwin Junker de Mexico, S. de R.L. de C.V.

Blvd. Bernardo Quintana #7001
Torre 2, #1203
Centro Sur Querétaro
Qro., C.P. 76079
Mexico

info@junker.com.mx
+52 442 1995111

Erwin Junker Máquinas Ltda.

Estrada do Capivari 751
Cep 09838-900
S.B. do Campo, São Paulo
Brazil

info@junker-group.com.br
+55 11 4153-9645
+55 11 4397-6008

LTA Industrial Air Cleaning Systems, Inc.

2541 Technology Drive, #410
Elgin, IL 60124
USA

info@lta-filter.com
+1 847 4880406
www.lta-filter.com

ZEMA Zselics Ltda.

Estrada do Capivari 741
Cep 09838-900
S.B. do Campo, São Paulo
Brazil

zema@zema.com.br
+55 11 4397-6000
www.zema.com.br

ASIA

Erwin Junker Maschinenfabrik GmbH Shanghai Representative Office

Unit 1003, Floor 10
Tower II Kerry Ever Bright City
Enterprise Center
No. 209 Gonghe Road
200070 Shanghai
P.R. China

info@junker.com.cn
+86 21 61438528

Erwin Junker Machinery (Shanghai) Co., Ltd.

Section D, Floor 6, Building 16#
No.69 Xi Ya Road
Waigaoqiao Free Trade Zone
200131 Shanghai
P.R. China

services@junker.com.cn
+86 2150 463525

Erwin Junker Maschinenfabrik GmbH India Branch Office

Office No. 805, Deron Heights
Baner Road,
Pune 411 045
India

info@junker.in
+91 20 27293403